

Towards a coupled paradigm of NH₃-CO₂ biosphere-atmosphere exchange modelling

Frederik Schrader¹ | Jan Willem Erisman^{2,3} | Christian Brümmer¹

¹Thünen Institute of Climate-Smart Agriculture, Braunschweig, Germany

²Cluster Earth and Climate, Department of Earth Sciences, Vrije Universiteit Amsterdam, Amsterdam, The Netherlands

³Louis Bolk Institute, Driebergen, The Netherlands

Correspondence

Frederik Schrader, Thünen Institute of Climate-Smart Agriculture, Braunschweig, Germany.

Email: frederik.schrader@thuenen.de

Funding information

Umweltbundesamt, Grant/Award Number: FKZ 3715512110; Bundesministerium für Bildung und Forschung, Grant/Award Number: FKZ 01LN1308A

Abstract

Stomatal conductance, one of the major plant physiological controls within NH₃ biosphere-atmosphere exchange models, is commonly estimated from semi-empirical multiplicative schemes or simple light- and temperature-response functions. However, due to their inherent parameterization on meteorological proxy variables, instead of a direct measure of stomatal opening, they are unfit for the use in climate change scenarios and of limited value for interpreting field-scale measurements. Alternatives based on H₂O flux measurements suffer from uncertainties in the partitioning of evapotranspiration at humid sites, as well as a potential decoupling of transpiration from stomatal opening in the presence of hygroscopic particles on leaf surfaces. We argue that these problems may be avoided by directly deriving stomatal conductance from CO₂ fluxes instead. We reanalysed a data set of NH₃ flux measurements based on CO₂-derived stomatal conductance, confirming the hypothesis that the increasing relevance of stomatal exchange with the onset of vegetation activity caused a rapid decrease of observed NH₃ deposition velocities. Finally, we argue that developing more mechanistic representations of NH₃ biosphere-atmosphere exchange can be of great benefit in many applications. These range from model-based flux partitioning, over deposition monitoring using low-cost samplers and inferential modelling, to a direct response of NH₃ exchange to climate change.

KEYWORDS

ammonia, Ball-Woodrow-Berry, CO₂, modelling, nutrients/nitrogen, stomata

1 | INTRODUCTION

Excessive dry deposition of reactive nitrogen has long been recognized as a major threat to both the environment and human health alike. It can lead to shifts in biodiversity, especially in natural ecosystems, phytotoxic effects, elevated greenhouse gas emissions, as well as respiratory and other health-related issues (Erisman et al., 2013). Ammonia (NH₃) is considered to be one of the most important constituents of total

reactive nitrogen, with global emission estimates ranging from 46 to 85 Tg N/year, likely more than half of which originate from agricultural production (Sutton et al., 2013). The accurate representation of NH₃ biosphere-atmosphere exchange within models is thus of great importance to build an adequate set of tools necessary to assess the whole lifecycle and impacts of reactive nitrogen compounds—from emission sources, over transport and chemical reactions in air, to their deposition. The difficulty with the quantification of ammonia air-surface exchange

This is an open access article under the terms of the Creative Commons Attribution License, which permits use, distribution and reproduction in any medium, provided the original work is properly cited.

© 2020 The Authors. *Global Change Biology* published by John Wiley & Sons Ltd

is that NH_3 can easily be absorbed and desorbed, and the exchange is highly variable in space and time. There have been considerable efforts to improve the parameterization of the bidirectional NH_3 exchange estimates in recent years (Massad, Nemitz, & Sutton, 2010; Personne et al., 2009; Wichink Kruit et al., 2010; Zhang, Wright, & Asman, 2010, and others); however, major uncertainties still prevail.

For instance, Schrader et al. (2016), among others, have recently highlighted uncertainties with the treatment of the non-stomatal pathway that can generally be attributed to (a) computational effort associated with a more realistic treatment of bidirectionality in the fluxes (e.g. Flechard, Fowler, Sutton, & Cape, 1999; Sutton, Burkhardt, Guerin, Nemitz, & Fowler, 1998) and (b) a lack of available measurement data across a wide range of ecosystems and pollution levels that are necessary for calibration and validation of new schemes (Flechard et al., 2013). Additionally, Flechard et al. (2013) note a lack of coupling of the exchange processes of different chemical compounds in current models. This include not only the often-neglected gas-particle interconversion within and above the canopy, or the still rather unrefined treatment of $\text{NH}_3\text{-SO}_2$ codeposition parameterizations based on relatively few observations (Nemitz, Milford, & Sutton, 2001; Wichink Kruit et al., 2017), but also within the representation of stomatal exchange. Most chemistry transport models (CTMs) nowadays employ multiplicative Jarvis (1976)-type functions or other (semi-)empirical approaches for modelling stomatal conductance (e.g. Simpson et al., 2012; Van Zanten, Sauter, Wichink Kruit, Van Jaarsveld, & Van Pul, 2010)—one of the most important plant physiological controls of NH_3 exchange. However, these models might be unfit for tasks that require direct site-specific measurements of the stomatal conductance instead of parameterizations based on proxy variables. Many measurement sites that are used for measuring and modelling NH_3 exchange are readily equipped with instrumentation that may be used to directly infer stomatal conductance from existing observations. We suggest leveraging these observations to avoid uncertainty associated with empirical approaches that were only built to be, on average, representative for a large number of potentially different sites within one land-use class.

One commonly used approach is to model the stomatal conductance based on measured fluxes of H_2O (e.g. Shuttleworth, 2012). However, these often suffer from an inherent uncertainty in the partitioning of transpiration and evaporation, especially at humid sites, where the latter is expected to be significant. Tower-based measurements of H_2O can generally only be representative for an ecosystem-integrated flux of evapotranspiration. Even if it can be partitioned successfully, recent research hints at a potential decoupling of transpiration fluxes and stomatal opening in the presence of hygroscopic particles on leaves (Grantz, Zinsmeister, & Burkhardt, 2018). Similar problems arise from directly inferring stomatal conductance of NH_3 from dry periods (e.g. Nemitz, Sutton, Wyers, & Jongejan, 2004), assuming that deposition to non-stomatal surfaces is negligible below a certain relative humidity threshold. While this assumption may be valid to a certain degree given our current understanding of NH_3 exchange processes, measuring NH_3 exchange in itself is still highly uncertain and few studies span a long enough time to gather sufficient high-quality

data during dry periods for a valid fit. Finally, purely empirical stomatal conductance parameterizations currently cannot account for stomatal responses to rising CO_2 concentrations (Ainsworth & Rogers, 2007), making them unfit for global change scenario modelling.

With this study, we aim to make a case for the use of a CO_2 exchange-based treatment of the stomatal pathway within the context of NH_3 dry deposition inferential modelling. Through the stomata, CO_2 and NH_3 share a common major exchange pathway, and the underlying physiological mechanisms of CO_2 biosphere-atmosphere exchange are generally well understood. Since the emergence of continent-wide research infrastructures for monitoring CO_2 exchange, such as ICOS or NEON, and even global networks like FLUXNET, CO_2 exchange measurements have become widely available, with the eddy covariance method as the de facto standard measurement technique. The limited NH_3 exchange studies are often carried out at existing flux towers within one of those networks, and it is only natural to want to use as much additional available information as possible to improve our estimates of reactive nitrogen deposition. Further to pure modelling studies, information gained about stomatal behaviour may help interpret direct NH_3 flux measurements, as recently demonstrated by Hansen et al. (2017) and in the article at hand. But not only experimental studies at individual sites with standard half-hourly concentration measurements may benefit—it may also pave the road towards a valid low-cost model-based NH_3 deposition monitoring network. Such a network could equip existing flux towers with inexpensive slow-response sensors, derive site-specific parameterizations for the non-stomatal pathway as well as corrections for the lowered temporal resolution (Schrader, Schaap, Zöll, Kranenburg, & Brümmer, 2018) and use stomatal conductance estimates directly inferred from available CO_2 flux measurements. Finally, new knowledge gained from these applications can be useful to evaluate the potential benefits of coupling CO_2 and NH_3 exchange within large-scale CTMs.

In the following, we will briefly outline the fundamental assumptions and equations behind modern bidirectional NH_3 exchange models. We propose coupling such models to a well-established function that relates CO_2 fluxes to stomatal conductances, and discuss in detail the potential benefits of doing so. One example is given in a case study on how we used CO_2 -derived stomatal conductance to support the interpretation of an NH_3 flux measurement data set. The results are used to confirm a hypothesized ecosystem response that could not be explained with empirical models alone in an earlier analysis. In the end, we discuss options for how to incorporate existing information about CO_2 exchange in modelling and data analysis workflows, as well as future perspectives for the development of more mechanistic NH_3 exchange models.

2 | MODELLING BIOSPHERE-ATMOSPHERE EXCHANGE OF AMMONIA

2.1 | Basic concepts

Biosphere-atmosphere exchange of NH_3 is commonly modelled using an inferential resistance analogy, that is, the total NH_3 flux

density at a given time, F_t ($\mu\text{g m}^{-2} \text{s}^{-1}$), is estimated from a measured or modelled ambient concentration at a certain reference height, χ_a ($\mu\text{g/m}^3$), minus the canopy compensation point, χ_c ($\mu\text{g/m}^3$), divided by the sum of the aerodynamic and quasi-laminar boundary layer resistances, R_a (s/m) and R_b (s/m) respectively (Equation 1). By convention, a negative flux is directed to the surface and a positive flux is directed to the atmosphere.

$$F_t = -\frac{\chi_a - \chi_c}{R_a + R_b} \quad (1)$$

χ_c can be interpreted as the equilibrium air NH_3 concentration at the mean notional height of trace gas exchange and is calculated as:

$$\chi_c = \frac{\chi_s \cdot R_s^{-1} + \chi_a \cdot (R_a + R_b)^{-1}}{(R_a + R_b)^{-1} + R_s^{-1} + R_w^{-1}}, \quad (2)$$

for a simple single-layer model with parallel stomatal and non-stomatal pathways for surface exchange of NH_3 (Figure 1a; Nemitz et al., 2001). R_s (s/m) and R_w (s/m) are the stomatal and non-stomatal resistance respectively. The parameterization of R_s is discussed in detail in the rest of this manuscript; R_w is most commonly modelled using humidity response functions (Sutton & Fowler, 1993), often with additional terms used to describe the effects of other atmospheric constituents on deposition (Massad, Nemitz, et al., 2010; Nemitz et al., 2001; Wichink Kruit et al., 2017). The stomatal pathway is nowadays usually modelled under consideration of a non-zero, near-surface air NH_3 concentration in equilibrium with NH_3 in the apoplastic fluid, called the stomatal compensation point, χ_s ($\mu\text{g/m}^3$), which allows for the representation

of bidirectional fluxes (i.e. both deposition and emission) within the model. It can be parameterized based on tabulated values for different ecosystems, direct or indirect estimates of deposition history to the site or more mechanistic plant physiological approaches that directly relate the compensation point to the C- and N-metabolisms at the leaf level (Massad, Nemitz, et al., 2010; Massad, Tuzet, Loubet, Perrier, & Cellier, 2010). Note that some researchers apply a similar concept to the non-stomatal pathway, with a non-stomatal compensation point, χ_w ($\mu\text{g/m}^3$), representing an air NH_3 concentration in equilibrium with NH_3 solved in water films or otherwise adsorbed to surfaces (Flechard et al., 2013; Van Zanten et al., 2010; Wichink Kruit et al., 2010). Even so, to date, many CTMs still employ a deposition-only paradigm for non-stomatal exchange, which is in contrast with observations of emission fluxes that are likely due to NH_3 release from non-stomatal surfaces (Wentworth et al., 2016). However, they are much more straightforward to be parameterized from micrometeorological measurements. In general, all models using the resistance analogy consider the surface component as a static component where memory effects are not taken into account. Prior deposition of NH_3 and/or other components affects, for example, the acidity of water layers, the aerosol composition and the χ_w and χ_s concentrations.

For convenience, the model may be simplified to a strictly serial structure (Figure 1b) with a foliar resistance, R_f (s/m) and a foliar compensation point (sometimes called 'total compensation point'), χ_f ($\mu\text{g/m}^3$), borrowing the notation of Wichink Kruit et al. (2010). An even further simplification to a quasi-unidirectional variant (Figure 1c) in which the effects of the compensation point are integrated in an effective foliar resistance, R_f^* (s/m) is possible and sometimes done to enforce compatibility with the concept of a deposition velocity. However, note that R_f^* can be negative in the case of emission fluxes, even though that is generally an ill-defined concept in a resistance modelling framework. R_f is equal to the sum of R_s and R_w ; the derivation of expressions for χ_f and R_f^* is straightforward and documented, for example, in Van Zanten et al. (2010). We here calculate χ_f as

$$\chi_f = \frac{R_f}{R_w} \cdot \chi_w + \frac{R_f}{R_s} \cdot \chi_s, \quad (3)$$

and R_f^* as

$$R_f^* = \frac{(R_a + R_b) \cdot \chi_f + R_f \cdot \chi_a}{\chi_a - \chi_f}. \quad (4)$$

The reciprocal of any resistance is called the corresponding conductance, that is, $R_x^{-1} = G_x$. Both are used throughout this text, since conductances are the more commonly used quantity in some disciplines which we borrow concepts from. They have the additional advantage of being directly (instead of inversely) proportional to the flux, as well as directly relatable to deposition velocities. Note that the units used in this context are sometimes inconsistent across communities: while micrometeorologists usually express conductances as length per time unit, plant physiologists tend to work with moles per area per second. We here follow the former convention unless specified otherwise.

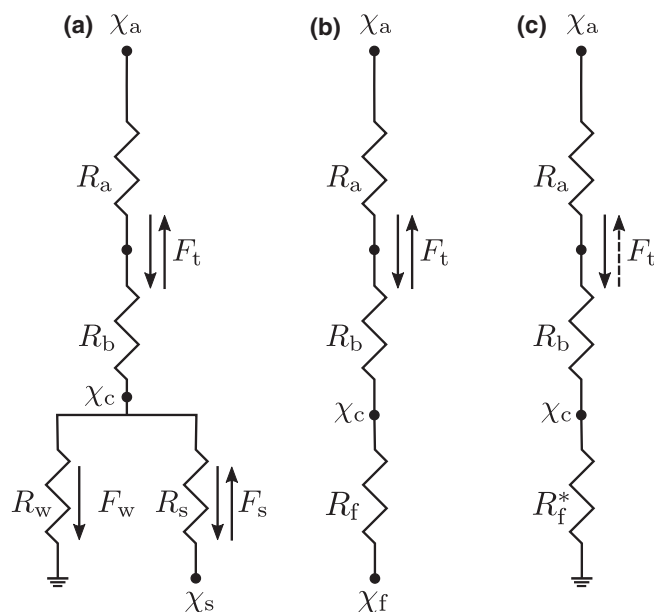

FIGURE 1 (a) Common structure of a canopy compensation point model with a unidirectional non-stomatal and a bidirectional stomatal NH_3 exchange pathway. (b) Serial bidirectional simplification with foliar resistance and foliar compensation point. (c) Serial unidirectional simplification with effective foliar resistance

2.2 | Stomatal controls and NH₃-CO₂ coupling

The stomatal resistance to NH₃ exchange, or its inverse, the stomatal conductance G_s (m/s), can be modelled using a number of different approaches: Most commonly, CTMs employ a multiplicative Jarvis (1976)-type scheme, such as the one of Emberson, Ashmore, Cambridge, Simpson, and Tuovinen (2000), which estimates the stomatal conductance as the product of a baseline resistance (or conductance) and a number of stress functions based on environmental factors (Flechard et al., 2013). Other authors use relatively simple light- and/or temperature-response functions in the absence of more detailed measurements, such as the one of Wesely (1989). However, these models are usually not suitable to directly incorporate measurable effects of rising greenhouse gas concentrations and the physiological effects that are associated with them (Ainsworth & Rogers, 2007; Leakey et al., 2009). They also often rely on certain land-use-specific effective parameters to be used over a wide array of ecosystems that can be aggregated into one class, but do not incorporate site-specific effects other than meteorological conditions. Finally, these models are usually used with ambient measurements of relative humidity, temperature and other environmental factors as input data, even though the actual flux-controlling conditions near the surface may very well be significantly different. While this weakness is not inherently built into the models' structure and they can theoretically be used with surface values of the respective variables instead, this may lead to bias when they were originally parameterized on ambient measurements. However, whether or not modelling these processes with surface variables is possible and meaningful strongly depends on an individual models' configuration, spatial resolution and degree of simplification of related processes.

One approach to avoid these issues and to incorporate as much information about a specific ecosystem into their models as possible is to rely on using measured H₂O flux-based estimates of stomatal conductance (Shuttleworth, 2012). These, in turn, suffer from a number of uncertainties due to the non-trivial partitioning of measured evapotranspiration (ET) into evaporation (E) from wet surfaces and transpiration (T) through the stomata, which can be especially problematic at very humid sites where ground-based fluxes and loss of water from leaf surfaces are a significant part of ET . Additional bias may be introduced from 'wick-effects' due to hygroscopic particles lining the walls of the stomatal cavity, called 'hydraulic activation of stomata' in the recent literature (Burkhardt, 2010; Burkhardt, Basi, Pariyar, & Hunsche, 2012), which can lead to a decoupling of T and G_s (Grantz et al., 2018).

We argue that these issues may largely be avoided by basing site-specific estimates of G_s on measured or modelled fluxes of CO₂ instead of H₂O. CO₂ fluxes are usually measured with the same instrumentation as H₂O (infrared gas analysers), are a routine measurement at many existing flux sites and tower networks (such as ICOS: Franz et al., 2018; or NEON: SanClements et al., 2014) and the underlying exchange processes are generally considered well understood. They are therefore suitable to directly base estimates of G_s to be used for modelling other compounds' exchange fluxes

on site-specific data instead of uncertain empirical approaches. Additionally, CO₂ flux-based estimates of G_s may be used as an interpretation tool for measured fluxes of gaseous compounds that are exchanged via the stomata, such as NH₃ or NO₂.

We propose to use the well-known Ball-Woodrow-Berry model (Ball, Woodrow, & Berry, 1987) to derive G_s from measured or modelled fluxes of CO₂. It can be written as:

$$g_s = m \cdot \frac{A_n \cdot h_s}{C_s} + b, \quad (5)$$

where m (-) is the slope and b (mol m⁻² s⁻¹) is the offset (minimum stomatal conductance) of the Ball-Woodrow-Berry function. For C₃ plants, m and b are commonly assumed to be around 9 and 0.01 mol m⁻² s⁻¹ respectively (Collatz, Ball, Grivet, & Berry, 1991; Sellers et al., 1996). Naturally these parameters are also subject to uncertainty, but we assume that the benefit of directly relating G_s to photosynthetic activity instead of similarly uncertain parameterizations based on proxy variables outweighs this fact. h_s is the leaf surface relative humidity (expressed as a fraction of 1) and C_s (ppm) is the leaf surface concentration of CO₂. The latter can be obtained through simple resistance modelling-based extrapolation from measured or modelled concentrations and fluxes at the reference height to the notional height of trace gas exchange. A_n is net CO₂ uptake (μmol m⁻² s⁻¹). Lowercase g_s in Equation (5) indicates that values obtained through this method are representative for leaf-level fluxes; bulk canopy G_s can be obtained from an up-scaling via measurements or modelled estimates of the leaf area index, as outlined in detail, for example, by Sellers, Berry, Collatz, Field, and Hall (1992) and Anderson, Norman, Meyers, and Diak (2000). To use it in an NH₃ inferential modelling context, the resulting bulk canopy G_s needs to be scaled by the ratio of NH₃ to H₂O molecular diffusivities.

3 | CASE STUDY

3.1 | Site description and measurement setup

Fast-response measurements of CO₂ and NH₃ were carried out at a temperate ombrotrophic bog in North-western Germany ('Bourtanger Moor') from February to May 2014. Vegetation at the site is dominated by bog heather (*Erica tetralix*), purple moor-grass (*Molinia caerulea*), cotton grass (*Eriophorum vaginatum*, *E. angustifolium*) and few scattered birches (*Betula pubescens*) and Scots pines (*Pinus sylvestris*). CO₂ concentrations were measured with an open-path infrared gas analyser (IRGA; LI-7500; LI-COR Biosciences) and NH₃ concentrations with a quantum cascade laser absorption spectrometer (Mini QC-TILDAS-76; Aerodyne Research, Inc.), both at a sampling frequency of 10 Hz. These high-frequency concentration measurements were used in conjunction with 10 Hz data from a 3D sonic anemometer (R3-50; Gill Instruments) to calculate half-hourly biosphere-atmosphere exchange fluxes of CO₂ and NH₃ using the eddy covariance technique. For a detailed site description and an in-depth discussion of data acquisition and post-processing steps,

the reader is referred to Hurkuck, Brümmer, and Kutsch (2016) and Zöll et al. (2016).

3.2 | Reanalysis of observed NH_3 fluxes

NH_3 fluxes at the 'Bourtanger Moor' field site showed a sudden decrease in deposition around 15 March 2014, which in part coincided with a decrease in concentrations (Zöll et al., 2016). However, concentrations increased again later during the campaign whereas fluxes remained at a very low level (Figure 2a), and the observed deposition velocities (i.e. essentially concentration-normalized flux rates) showed a similar pattern with a gradual decrease from up to 0.7 cm/s down to daily averages of less than 0.2 cm/s around mid- to end-March and staying on that level thereafter (Figure 2b). This coincided with a pressure drop, increasing precipitation and minimum air temperatures exceeding 5°C for the first time at the site in 2014 (Zöll et al., 2016). Relative humidity was consistently very high (daily averages between 80% and 100%). The campaign-averaged NH_3 concentration was 11 $\mu\text{g}/\text{m}^3$ with management-related peaks in mid-March (>20 $\mu\text{g}/\text{m}^3$ daily average on 12 and 13 March) and early April (>20 $\mu\text{g}/\text{m}^3$ daily average from 1 to 4 April). Zöll et al. (2016) hypothesized that, among other reasons, this decline in deposition velocity

may be attributed to the combined effects of an onset of vegetation activity and an increase in the stomatal compensation point due to rising temperatures. An increasing compensation point is relatively straightforward to explain from theory, as it depends exponentially on temperature, accounting for the combined effect of gas solubility and dissociation of NH_3 . However, observational evidence for an increasing stomatal contribution to the total flux is necessary. In this case study, we examine how CO_2 flux-derived stomatal conductance can help us accept or reject the hypothesis of a stomatal effect on the lowered deposition velocity.

The traditional approach of separating measured fluxes into those measured during dry periods ($\text{RH} < 70\%$ or similar thresholds) and fitting a light-response function to the resulting observed foliar resistance (e.g. Nemitz et al., 2004) was not possible at this site due to the constantly humid conditions throughout the measurement campaign (cf. Zöll et al., 2016). Similarly, a permanently humid topsoil and even occasional ponding limited the applicability of latent heat flux measurements as a proxy for transpiration, thereby preventing their use in the derivation of a bulk stomatal conductance for H_2O .

Therefore, and as a test for its feasibility for the use in NH_3 modelling studies, CO_2 fluxes measured by Hurkuck et al. (2016) were used to derive bulk canopy stomatal conductance for NH_3 using the Ball–Woodrow–Berry model with canopy upscaling as described in

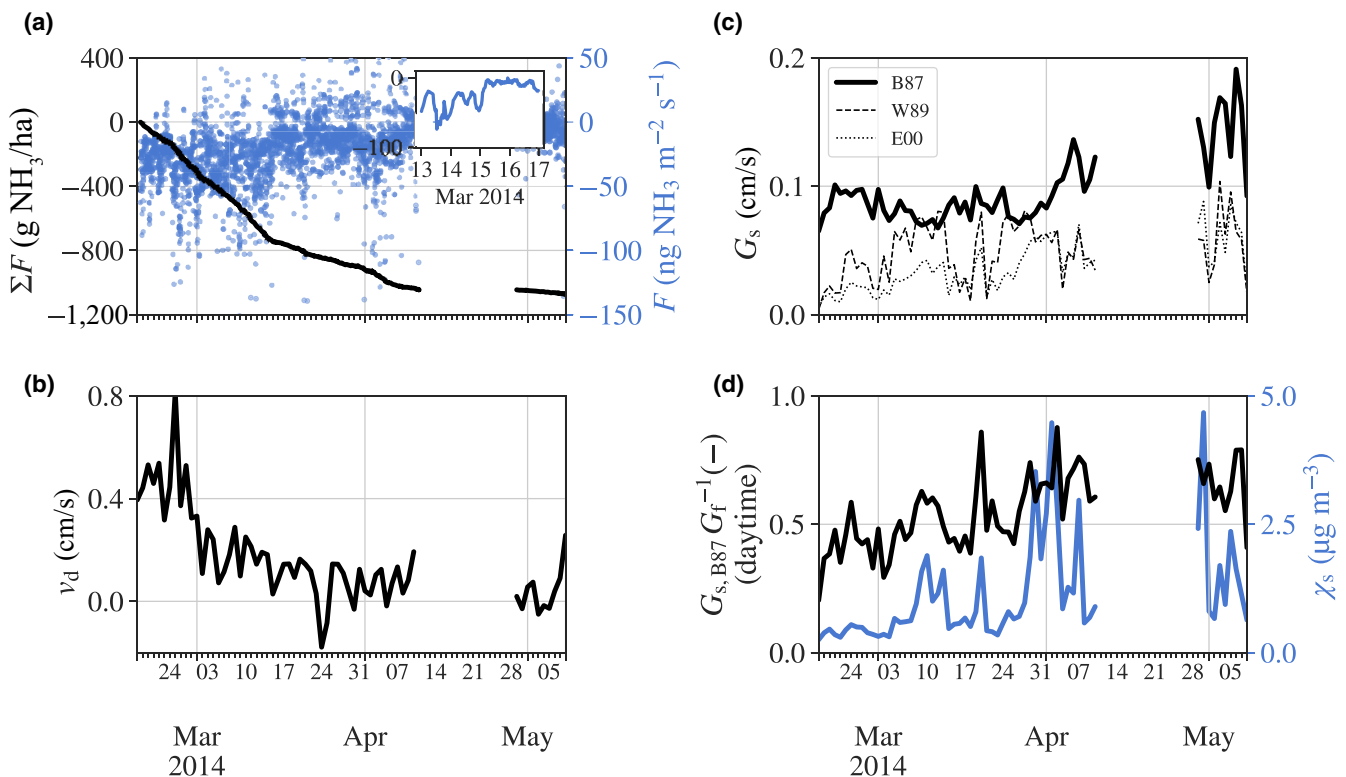

FIGURE 2 Results from the 'Bourtanger Moor' case study. (a) Half-hourly NH_3 mass flux density (blue dots) and gap-filled cumulative NH_3 flux (black line) obtained with eddy covariance measurements. Small inset shows sudden decline in 6 hr moving average flux densities around 15 March. Negative fluxes indicate deposition. (b) Observed daily average NH_3 dry deposition velocity. (c) Modelled daily average stomatal conductance obtained from two empirical models (W89: Wesely, 1989; E00: Emberson et al., 2000) and from eddy covariance fluxes of CO_2 using the Ball–Woodrow–Berry model (B87: Ball et al., 1987) (d) Daily average contribution of stomatal conductance to total foliar conductance (black line) and stomatal compensation point (blue line) during daytime using the Ball–Woodrow–Berry model

Sellers et al. (1992). CO_2 net ecosystem exchange (NEE) was partitioned into gross primary productivity (GPP) and ecosystem respiration (R_{eco}) following Reichstein et al. (2005), as described in Hurkuck et al. (2016), and the resulting GPP was used as bulk canopy A_n in the canopy-scale Ball-Woodrow-Berry model. G_s obtained via this procedure was used to model fluxes of NH_3 using the parameterization of a two-layer canopy compensation point model after Massad, Nemitz, et al. (2010). Note that for semi-natural peatland sites like the 'Bourtanger Moor', the model is essentially reduced to a one-layer model by setting the ground layer resistance to infinity, due to the difficult partitioning of ground layer and other non-stomatal fluxes in unmanaged ecosystems. The minimum resistance and temperature response used in the non-stomatal resistance parameterization were recently reported to be likely too high for some sites (Schrader et al., 2016). Thus, we derived site-specific values for these two parameters by assuming that foliar resistances derived from night-time flux measurements of NH_3 were representative for the non-stomatal resistance, R_w , that is, assuming perfect stomatal closure at night. We then globally minimized the sum of squared residuals between measured and modelled non-stomatal conductance using a Python 3.7 implementation of the differential evolution method (scipy.optimize.differential_evolution; SciPy version 1.1.0; Storn & Price, 1997; Virtanen et al., 2020) with bounds 0–1,000 s/m for minimum R_w and 0–1°C⁻¹ for the temperature response parameter. Optimal minimum non-stomatal resistance and temperature response parameter were 32.8 s/m and 0.12°C⁻¹ respectively. All other parameters were set to default values for short semi-natural vegetation following Massad, Nemitz, et al. (2010) or to measured values as reported in detail in Zöll et al. (2016). Modelled results were used to interpret the observed flux patterns during the measurement campaign with focus on the validity of explaining the 'tipping point' in mid-March with an onset of vegetation activity.

3.3 | Results and discussion

Daily averages of stomatal conductance of NH_3 derived from CO_2 flux measurements were relatively constant until the last week of March 2014, after which they exhibited a strong and seemingly linear increase up to more than twice their initial magnitude, whereas a selection of empirical models (Emberson et al., 2000; Wesely, 1989) show an initial increase at the beginning of the measurement campaign (mid-February) and remain on a relatively low level below 0.1 cm/s with an only slightly positive trend (Figure 2c). At first glance, CO_2 -derived stomatal conductance does not appear to be correlated with the strong decrease in observed deposition velocity (Figure 2c), while empirically modelled stomatal conductance seems to be anti-correlated to a certain degree. That said, it is unlikely that the decrease in deposition velocities can be attributed to the stomatal pathway in a mono-causal manner. In fact, this decrease is also observed in night-time data, where stomatal fluxes are assumed to play a negligible role, and both observed night-time foliar conductance (as a proxy for the non-stomatal conductance) and site-calibrated

modelled non-stomatal conductance decrease at the same time. This is further reflected in an increasing contribution of CO_2 -derived stomatal conductance to daytime foliar conductance from a minimum of around 20% up to more than 80%, which is apparently anti-correlated with observed deposition velocities (Figure 2d). Note that it follows from the governing equations of the resistance framework used in this study that this relation ($G_s G_f^{-1}$) is approximately equal to the ratio of stomatal to total exchange flux when the compensation point is considerably smaller than the ambient NH_3 concentration.

Indeed a regression of daytime observed deposition velocities against daytime CO_2 -derived stomatal conductance contribution to the foliar conductance shows a significant anti-correlation ($r = -.52$, intercept = 0.46, slope = -0.53 , two-sided p -value [H_0 : slope is zero] $< .001$; Figure 3), indicating that an increase in stomatal contribution to the flux leads to a decrease in the deposition velocity. This may seem counterintuitive at first, especially considering that the foliar conductance remains relatively constant from early March until the end of the campaign. It may, however, be explained by a concurrent increase in temperatures and, consequently, the stomatal compensation point throughout the measurement period (Figure 2d). The 'Bourtanger Moor' site has historically received annual N-deposition of up to fivefold above its critical load, with an estimated total (wet and dry) deposition in the order of 25 kg N ha⁻¹ year⁻¹ (Hurkuck et al., 2014). Since the stomatal compensation point is expected to be dependent on historical N-inputs, it can reasonably be assumed to be significant at this site. To put it into context, the parameterization of Massad, Nemitz, et al. (2010) predicts a stomatal emission potential of 635 for this site, which is well above the average (mean 502, median 190) for short semi-natural and forest ecosystems found in an extensive literature review by the same authors. An increase in the contribution of the stomatal conductance to the foliar conductance directly leads to an increase in the contribution of the stomatal compensation point to the foliar compensation point (Figure 4a).

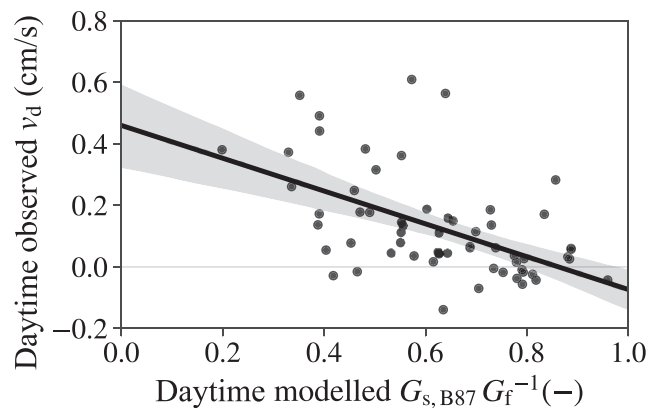

FIGURE 3 Linear regression of observed daily mean daytime NH_3 dry deposition velocities against daytime ratio of CO_2 flux-derived stomatal conductance to total modelled foliar conductance. One outlier ($v_d > 1.5$ cm/s on 25 February 2014) was removed from the regression data set. The shaded area envelopes a 95% confidence interval of the regression based on 10,000 bootstrap samples

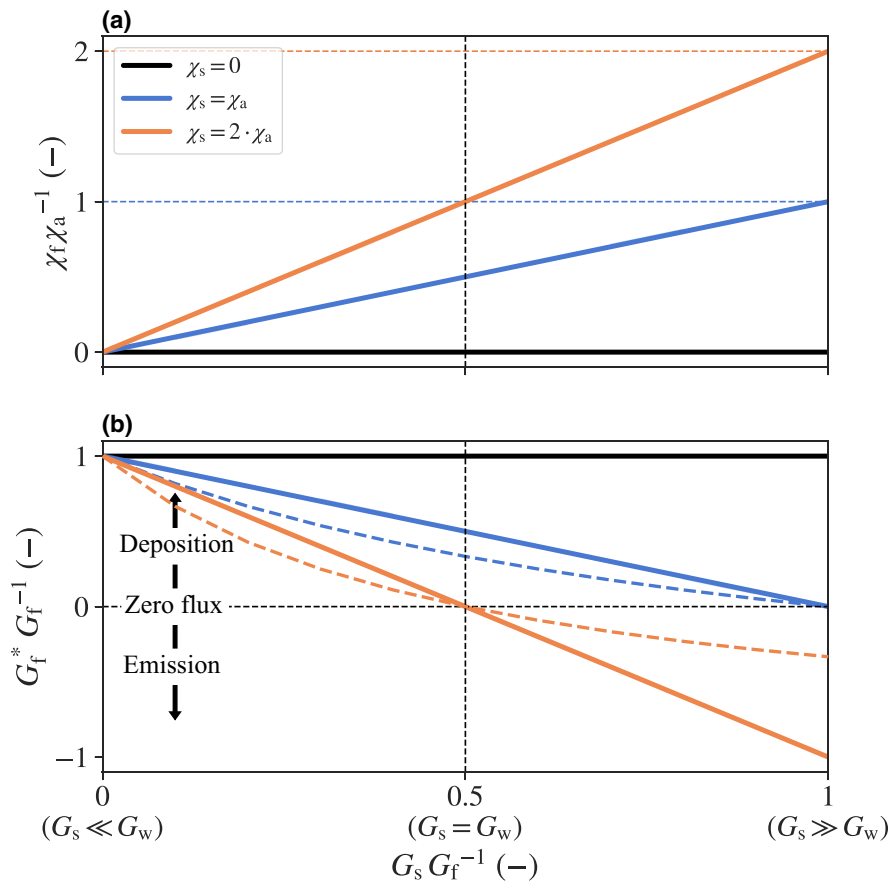

FIGURE 4 Theoretical explanation of the results from the 'Bourtanger Moor' case study. (a) Evolution of the ratio of the foliar compensation point to ambient NH_3 concentration at the reference height and (b) the ratio of effective to actual foliar conductance with increasing stomatal contribution to the foliar conductance and varying stomatal compensation point levels. Black lines: no stomatal compensation point; blue lines: stomatal compensation point equals to ambient concentrations; orange lines: stomatal compensation point twice as large as ambient concentrations. Dashed lines: Aerodynamic and quasi-laminar conductance equal in magnitude to foliar conductance; solid lines: aerodynamic and foliar conductance neglected. The non-stomatal pathway is assumed to be unidirectional (i.e. a hypothetical non-stomatal compensation point would be zero) in all cases

Assuming that the non-stomatal compensation point is zero, which is commonly done in modelling NH_3 exchange, this also directly leads to a reduced NH_3 concentration gradient and therefore a reduced deposition velocity. We thus conclude that the hypothesis of Zöll et al. (2016) regarding a reduction of the deposition velocity at least partially due to the onset of vegetation activity is justified and likely plays a significant role in the observed flux patterns, based on our reanalysis using CO_2 -derived stomatal conductance.

Theoretically, the relationship explaining this phenomenon is linear when non-stomatal fluxes are modelled unidirectionally: If the stomatal compensation point is twice the air NH_3 concentration, a 50% contribution of the stomatal conductance to the foliar conductance means zero gradient and therefore zero flux. This is irrespective of the magnitude of the aerodynamic and boundary layer conductance. However, note that taking these into account the relationship of an effective foliar resistance to the actual foliar resistance becomes non-linear between the extreme cases of zero compensation point or compensation point equal to the ambient concentration at the reference height (Figure 4b).

The main uncertainties in this approach can be attributed to three sources, apart from noise or systematic errors that affect all measurements: (a) Potential bias in the CO_2 flux partitioning algorithm. The magnitude of GPP and thus of G_s is naturally directly affected by this. Recent evidence suggests that both of the most commonly applied methods—the night-time method of Reichstein et al. (2005) and the daytime method of Lasslop et al. (2010)—may exhibit bias

during different times of the day (Keenan et al., 2019). It is therefore strongly recommended to choose the partitioning algorithm carefully, and, if possible, validate it using independent measurements. Naturally, this does not apply when the stomatal conductance link is based on modelled instead of measured CO_2 fluxes. 2) Uncertainties in the parameters of the Ball–Woodrow–Berry model. These parameters are remarkably stable on a global scale and may therefore be set to a fixed value when used in CTMs (e.g. Franks, Berry, Lombardozzi, & Bonan, 2017 and references therein), but may exhibit substantial variation on the plot scale. The sensitivity of these parameters is dependent on both boundary conditions and the modelling framework itself and needs to be checked in context. 3) Uncertainties inherent to the NH_3 biosphere–atmosphere exchange scheme used. These are very much dependent on the specific implementation and parameter sets used and need to be estimated on a case-by-case basis. To our knowledge, no systematic effort at quantifying uncertainties in state-of-the-art NH_3 biosphere–atmosphere exchange models has been published in the recent literature.

4 | CONCLUSIONS AND FUTURE PERSPECTIVES

We successfully demonstrated that a model-driven approach for flux data analysis using CO_2 flux-derived stomatal conductance can help reveal otherwise hidden processes. Simple regression- and

observation-based approaches only indirectly allowed the conclusions here drawn from a leaf-level analysis of drivers for the biosphere-atmosphere exchange of NH_3 at the 'Bourtanger Moor' field site (Zöll et al., 2016). Yet, this case study is merely one example of how CO_2 flux data-based estimates of stomatal conductance can be used to improve our understanding of NH_3 biosphere-atmosphere exchange. There is great potential in improving the predictive power of inferential models, both on the field-scale, as well as in spatially explicit modelling studies, and global change projections, by linking NH_3 and CO_2 models at this shared pathway using well-known and easy-to-implement modelling tools. Potential applications include, but are certainly not limited to:

- Using CO_2 -derived stomatal conductances in a model-driven flux data analysis workflow to interpret direct flux measurements of NH_3 (as demonstrated in the case study).
- Coupling an NH_3 inferential and a photosynthesis model and using measured CO_2 data to validate the latter. This has recently been demonstrated in an NH_3 flux-partitioning study with the SURFATM- NH_3 model (Personne et al., 2009) by Hansen et al. (2017).
- Improving the predictive capabilities for global change projections from large-scale CTMs by joining CO_2 , NH_3 and potentially other compounds' exchange submodules, for example, following the example of Anav, Menut, Khvorostyanov, and Viovy (2012) for O_3 , as recognized by Flechard et al. (2013).
- Retrofitting existing flux tower networks such as ICOS with low-cost, low-labour NH_3 measurements (e.g. with passive samplers). Models for the non-stomatal pathway may be calibrated on short-term measurements of night-time NH_3 fluxes acquired with a roving system, and using correction factors accounting for the lowered temporal resolution compared to fast-response analysers (Schrader et al., 2018). The stomatal pathway can be modelled by validating (or calibrating) a coupled photosynthesis-stomatal conductance model (e.g. Collatz et al., 1991) on the existing CO_2 measurements, giving a continuous data set of stomatal conductance independent of data gaps in the CO_2 eddy covariance setups.

To achieve optimal suitability for local air quality and global change studies alike, future research should strive towards a more mechanistic representation of all biosphere-atmosphere exchange pathways. This is not limited to physiological controls, but also potential chemical interactions (e.g. Flechard et al., 1999). Long-term simultaneous micrometeorological measurements of both greenhouse gas and reactive nitrogen exchange across a wide range of ecosystems are desperately needed to further develop valid frameworks for modelling interrelations between them, and to accurately identify areas where action is necessary to mitigate negative effects of excess nitrogen deposition.

ACKNOWLEDGEMENTS

F.S. and C.B. greatly acknowledge financial support by the German Federal Ministry of Education and Research (BMBF) within the Junior

Research Group NITROSPHERE under support code FKZ 01LN1308A and the German Environmental Protection Agency (UBA) under grant no. FKZ 3715512110. We highly appreciate technical assistance in the field by Jeremy Ruffer and Jean-Pierre Delorme from Thünen Institute. Finally, we would like to acknowledge Undine Zöll and Miriam Hurkuck, who conducted the measurements at the 'Bourtanger Moor' site. The authors declare no conflict of interest.

ORCID

Frederik Schrader  <https://orcid.org/0000-0002-5668-3467>

Christian Brümmer  <https://orcid.org/0000-0001-6621-5010>

REFERENCES

- Ainsworth, E. A., & Rogers, A. (2007). The response of photosynthesis and stomatal conductance to rising $[\text{CO}_2]$: Mechanisms and environmental interactions. *Plant, Cell and Environment*, 30(3), 258–270. <https://doi.org/10.1111/j.1365-3040.2007.01641.x>
- Anav, A., Menut, L., Khvorostyanov, D., & Viovy, N. (2012). A comparison of two canopy conductance parameterizations to quantify the interactions between surface ozone and vegetation over Europe. *Journal of Geophysical Research: Biogeosciences*, 117, G03027. <https://doi.org/10.1029/2012JG001976>
- Anderson, M. C., Norman, J. M., Meyers, T. P., & Diak, G. R. (2000). An analytical model for estimating canopy transpiration and carbon assimilation fluxes based on canopy light-use efficiency. *Agricultural and Forest Meteorology*, 101(4), 265–289. [https://doi.org/10.1016/S0168-1923\(99\)00170-7](https://doi.org/10.1016/S0168-1923(99)00170-7)
- Ball, J. T., Woodrow, I. E., & Berry, J. A. (1987). A model predicting stomatal conductance and its contribution to the control of photosynthesis under different environmental conditions. In J. Biggins (Ed.), *Progress in photosynthesis research* (pp. 221–224). Dordrecht: Springer.
- Burkhardt, J. (2010). Hygroscopic particles on leaves: Nutrients or desiccants? *Ecological Monographs*, 80(3), 369–399. <https://doi.org/10.1890/09-1988.1>
- Burkhardt, J., Basi, S., Pariyar, S., & Hunsche, M. (2012). Stomatal penetration by aqueous solutions – An update involving leaf surface particles. *New Phytologist*, 196(3), 774–787. <https://doi.org/10.1111/j.1469-8137.2012.04307.x>
- Collatz, G. J., Ball, J. T., Grivet, C., & Berry, J. A. (1991). Physiological and environmental regulation of stomatal conductance, photosynthesis and transpiration: A model that includes a laminar boundary layer. *Agricultural and Forest Meteorology*, 54(2–4), 107–136. [https://doi.org/10.1016/0168-1923\(91\)90002-8](https://doi.org/10.1016/0168-1923(91)90002-8)
- Emberson, L., Ashmore, M., Cambridge, H. M., Simpson, D., & Tuovinen, J.-P. (2000). Modelling stomatal ozone flux across Europe. *Environmental Pollution*, 109(3), 403–413. [https://doi.org/10.1016/S0269-7491\(00\)00043-9](https://doi.org/10.1016/S0269-7491(00)00043-9)
- Erisman, J. W., Galloway, J. N., Seitzinger, S., Bleeker, A., Dise, N. B., Petrescu, A. M. R., ... de Vries, W. (2013). Consequences of human modification of the global nitrogen cycle. *Philosophical Transactions of the Royal Society B: Biological Sciences*, 368(1621), 20130116. <https://doi.org/10.1098/rstb.2013.0116>
- Flechard, C. R., Fowler, D., Sutton, M. A., & Cape, J. N. (1999). A dynamic chemical model of bi-directional ammonia exchange between semi-natural vegetation and the atmosphere. *Quarterly Journal of the Royal Meteorological Society*, 125(559), 2611–2641. <https://doi.org/10.1002/qj.49712555914>
- Flechard, C. R., Massad, R.-S., Loubet, B., Personne, E., Simpson, D., Bash, J. O., ... Sutton, M. A. (2013). Advances in understanding, models and parameterizations of biosphere-atmosphere ammonia exchange. *Biogeosciences*, 10(7), 5183–5225. <https://doi.org/10.5194/bg-10-5183-2013>

- Franks, P. J., Berry, J. A., Lombardozi, D. L., & Bonan, G. B. (2017). Stomatal function across temporal and spatial scales: Deep-time trends, land-atmosphere coupling and global models. *Plant Physiology*, 174(2), 583–602. <https://doi.org/10.1104/pp.17.00287>
- Franz, D., Acosta, M., Altimir, N., Arriga, N., Arrouays, D., Aubinet, M., ... Vesala, T. (2018). Towards long-term standardised carbon and greenhouse gas observations for monitoring Europe's terrestrial ecosystems: A review. *International Agrophysics*, 32, 439–455. <https://doi.org/10.1515/intag-2017-0039>
- Grantz, D. A., Zinsmeister, D., & Burkhardt, J. (2018). Ambient aerosol increases minimum leaf conductance and alters the aperture–flux relationship as stomata respond to vapor pressure deficit (VPD). *New Phytologist*, 219(1), 275–286. <https://doi.org/10.1111/nph.15102>
- Hansen, K., Personne, E., Skjøth, C. A., Loubet, B., Ibrom, A., Jensen, R., ... Boegh, E. (2017). Investigating sources of measured forest-atmosphere ammonia fluxes using two-layer bi-directional modelling. *Agricultural and Forest Meteorology*, 237–238, 80–94. <https://doi.org/10.1016/j.agrformet.2017.02.008>
- Hurkuck, M., Brümmner, C., & Kutsch, W. L. (2016). Near-neutral carbon dioxide balance at a seminatural, temperate bog ecosystem. *Journal of Geophysical Research: Biogeosciences*, 121(2), 370–384. <https://doi.org/10.1002/2015JG003195>
- Hurkuck, M., Brümmner, C., Mohr, K., Grünhage, L., Flessa, H., & Kutsch, W. L. (2014). Determination of atmospheric nitrogen deposition to a semi-natural peat bog site in an intensively managed agricultural landscape. *Atmospheric Environment*, 97, 296–309. <https://doi.org/10.1016/j.atmosenv.2014.08.034>
- Jarvis, P. G. (1976). The interpretation of the variations in leaf water potential and stomatal conductance found in canopies in the field. *Philosophical Transactions of the Royal Society B: Biological Sciences*, 273(927), 593–610. <https://doi.org/10.1098/rstb.1976.0035>
- Keenan, T. F., Migliavacca, M., Papale, D., Baldocchi, D., Reichstein, M., Torn, M., & Wutzler, T. (2019). Widespread inhibition of daytime ecosystem respiration. *Nature Ecology & Evolution*, 3, 407–415. <https://doi.org/10.1038/s41559-019-0809-2>
- Lasslop, G., Reichstein, M., Papale, D., Richardson, A. D., Arneth, A., Barr, A., ... Wohlfahrt, G. (2010). Separation of net ecosystem exchange into assimilation and respiration using a light response curve approach: Critical issues and global evaluation. *Global Change Biology*, 16(11), 187–208. <https://doi.org/10.1111/j.1365-2486.2009.02041.x>
- Leakey, A. D. B., Ainsworth, E. A., Bernacchi, C. J., Rogers, A., Long, S. P., & Ort, D. R. (2009). Elevated CO₂ effects on plant carbon, nitrogen, and water relations: Six important lessons from FACE. *Journal of Experimental Botany*, 60(10), 2859–2876. <https://doi.org/10.1093/jxb/erp096>
- Massad, R.-S., Nemitz, E., & Sutton, M. A. (2010). Review and parameterisation of bi-directional ammonia exchange between vegetation and the atmosphere. *Atmospheric Chemistry and Physics*, 10(21), 10359–10386. <https://doi.org/10.5194/acp-10-10359-2010>
- Massad, R. S., Tuzet, A., Loubet, B., Perrier, A., & Cellier, P. (2010). Model of stomatal ammonia compensation point (STAMP) in relation to the plant nitrogen and carbon metabolisms and environmental conditions. *Ecological Modelling*, 221(3), 479–494. <https://doi.org/10.1016/j.ecolmodel.2009.10.029>
- Nemitz, E., Milford, C., & Sutton, M. A. (2001). A two-layer canopy compensation point model for describing bi-directional biosphere-atmosphere exchange of ammonia. *Quarterly Journal of the Royal Meteorological Society*, 127(573), 815–833. <https://doi.org/10.1002/qj.49712757306>
- Nemitz, E., Sutton, M. A., Wyers, G. P., & Jongejan, P. A. C. (2004). Gas-particle interactions above a Dutch heathland: I. Surface exchange fluxes of NH₃, SO₂, HNO₃ and HCl. *Atmospheric Chemistry and Physics Discussions*, 4(2), 1473–1517. <https://doi.org/10.5194/acpd-4-1473-2004>
- Personne, E., Loubet, B., Herrmann, B., Mattsson, M., Schjoerring, J. K., Nemitz, E., ... Cellier, P. (2009). SURFATM-NH₃: A model combining the surface energy balance and bi-directional exchanges of ammonia applied at the field scale. *Biogeosciences*, 6, 1371–1388. <https://doi.org/10.5194/bg-6-1371-2009>
- Reichstein, M., Falge, E., Baldocchi, D., Papale, D., Aubinet, M., Berbigier, P., ... Valentini, R. (2005). On the separation of net ecosystem exchange into assimilation and ecosystem respiration: Review and improved algorithm. *Global Change Biology*, 11(9), 1424–1439. <https://doi.org/10.1111/j.1365-2486.2005.001002.x>
- SanClements, M., Luo, H., Pingintha-Durden, N., Metzger, S., Zulueta, R., & Loescher, H. W. (2014). The national ecological observatory's terrestrial infrastructure: A standardized framework for decadal ecosystem observations at the continental scale. *leaps Newsletter*, 14, 23–26.
- Schrader, F., Brümmner, C., Flechard, C. R., Wichink Kruit, R. J., van Zanten, M. C., Zöll, U., ... Erisman, J. W. (2016). Non-stomatal exchange in ammonia dry deposition models: Comparison of two state-of-the-art approaches. *Atmospheric Chemistry and Physics*, 16(21), 13417–13430. <https://doi.org/10.5194/acp-16-13417-2016>
- Schrader, F., Schaap, M., Zöll, U., Kranenburg, R., & Brümmner, C. (2018). The hidden cost of using low-resolution concentration data in the estimation of NH₃ dry deposition fluxes. *Scientific Reports*, 8(1), 969. <https://doi.org/10.1038/s41598-017-18021-6>
- Sellers, P. J., Berry, J. A., Collatz, G. J., Field, C. B., & Hall, F. G. (1992). Canopy reflectance, photosynthesis and transpiration, III. A reanalysis using enzyme kinetics-electron transport models of leaf physiology. *Remote Sensing of Environment*, 42, 187–216. [https://doi.org/10.1016/0034-4257\(92\)90102-P](https://doi.org/10.1016/0034-4257(92)90102-P)
- Sellers, P. J., Randall, D. A., Collatz, G. J., Berry, J. A., Field, C. B., Dazlich, D. A., ... Bounoua, L. (1996). A revised land surface parameterization (SiB2) for atmospheric GCMs. Part I: Model formulation. *Journal of Climate*, 9(4), 676–705. [https://doi.org/10.1175/1520-0442\(1996\)009<0676:ARLSPF>2.0.CO;2](https://doi.org/10.1175/1520-0442(1996)009<0676:ARLSPF>2.0.CO;2)
- Shuttleworth, W. J. (2012). *Terrestrial hydrometeorology*. Chichester, UK: John Wiley & Sons Ltd.
- Simpson, D., Benedictow, A., Berge, H., Bergström, R., Emberson, L. D., Fagerli, H., ... Wind, P. (2012). The EMEP MSC-W chemical transport model – Technical description. *Atmospheric Chemistry and Physics*, 12(16), 7825–7865. <https://doi.org/10.5194/acp-12-7825-2012>
- Storn, R., & Price, K. (1997). Differential evolution – A simple and efficient heuristic for global optimization over continuous spaces. *Journal of Global Optimization*, 11(4), 341–359. <https://doi.org/10.1023/A:1008202821328>
- Sutton, M. A., Burkhardt, J. K., Guerin, D., Nemitz, E., & Fowler, D. (1998). Development of resistance models to describe measurements of bi-directional ammonia surface–atmosphere exchange. *Atmospheric Environment*, 32(3), 473–480. [https://doi.org/10.1016/S1352-2310\(97\)00164-7](https://doi.org/10.1016/S1352-2310(97)00164-7)
- Sutton, M. A., & Fowler, D. (1993). A model for inferring bi-directional fluxes of ammonia over plant canopies. In *Proceedings of the WMO conference on the measurement and modelling of atmospheric composition changes including pollution transport* (pp. 179–182). Geneva: WMO/GAW-91WMO. Retrieved from https://library.wmo.int/doc_num.php?explnum_id=9600
- Sutton, M. A., Reis, S., Riddick, S. N., Dragosits, U., Nemitz, E., Theobald, M. R., ... de Vries, W. (2013). Towards a climate-dependent paradigm of ammonia emission and deposition. *Philosophical Transactions of the Royal Society B: Biological Sciences*, 368(1621), 20130166. <https://doi.org/10.1098/rstb.2013.0166>
- Van Zanten, M. C., Sauter, F. J., Wichink Kruit, R. J., Van Jaarsveld, J. A., & Van Pul, W. A. J. (2010). *Description of the DEPAC module; Dry deposition modeling with DEPAC_GCN2010*. Bilthoven: RIVM.
- Virtanen, P., Gommers, R., Oliphant, T. E., Haberland, M., Reddy, T., Cournapeau, D., ... SciPy 1.0 Contributors. (2020). SciPy 1.0: Fundamental

- algorithms for scientific computing in Python. *Nature Methods*, 17, 261–272. <http://dx.doi.org/10.1038/s41592-019-0686-2>
- Wentworth, G. R., Murphy, J. G., Benedict, K. B., Bangs, E. J., Collett, J. L., & Collett Jr., J. L. (2016). The role of dew as a nighttime reservoir and morning source for atmospheric ammonia. *Atmospheric Chemistry and Physics Discussions*, 16, 1–36. <https://doi.org/10.5194/acp-16-7435-2016>
- Wesely, M. (1989). Parameterization of surface resistances to gaseous dry deposition in regional-scale numerical models. *Atmospheric Environment* (1967), 23(6), 1293–1304. [https://doi.org/10.1016/0004-6981\(89\)90153-4](https://doi.org/10.1016/0004-6981(89)90153-4)
- Wichink Kruit, R. J., Aben, J., de Vries, W., Sauter, F., van der Swaluw, E., van Zanten, M. C., & van Pul, W. (2017). Modelling trends in ammonia in the Netherlands over the period 1990–2014. *Atmospheric Environment*, 154, 20–30. <https://doi.org/10.1016/j.atmosenv.2017.01.031>
- Wichink Kruit, R. J., van Pul, W., Sauter, F. J., van den Broek, M., Nemitz, E., Sutton, M. A., ... Holtslag, A. (2010). Modeling the surface–atmosphere exchange of ammonia. *Atmospheric Environment*, 44(7), 945–957. <https://doi.org/10.1016/j.atmosenv.2009.11.049>
- Zhang, L., Wright, L. P., & Asman, W. A. H. (2010). Bi-directional air-surface exchange of atmospheric ammonia: A review of measurements and a development of a big-leaf model for applications in regional-scale air-quality models. *Journal of Geophysical Research-Atmospheres*, 115(20), D20310. <https://doi.org/10.1029/2009JD013589>
- Zöll, U., Brümmer, C., Schrader, F., Ammann, C., Ibrom, A., Flechard, C. R., ... Kutsch, W. L. (2016). Surface–atmosphere exchange of ammonia over peatland using QCL-based eddy-covariance measurements and inferential modeling. *Atmospheric Chemistry and Physics*, 16(17), 11283–11299. <https://doi.org/10.5194/acp-16-11283-2016>

How to cite this article: Schrader F, Erisman JW, Brümmer C. Towards a coupled paradigm of NH₃-CO₂ biosphere–atmosphere exchange modelling. *Glob Change Biol*. 2020;26: 4654–4663. <https://doi.org/10.1111/gcb.15184>